

Measuring the Impedance of Inductors and Transformers.

John F. Iannuzzi

Introduction

In many cases it is necessary to characterize the impedance of inductors and transformers. For instance, power supply designers are interested in characteristics such as DC resistance, resonance and inductance especially when custom components must be used in their designs. Under certain manufacturing or assembly conditions, it may be necessary to measure and sort components that have a wide tolerance. For circuit simulation and modeling, characteristics such as inter-winding capacitance and resonance, as well as DC resistance and inductance are necessary for accurate predictions of circuit performance.

This application note discusses a method for characterizing the impedance of inductors and transformers using the Circuit Sleuth Network/Impedance analyzer.

Inductor impedance measurement and the equivalent circuit model.

The test setup for measuring the impedance of an inductor is shown in figure 1. The inductor is a commercially available component. The manufacturers specified inductance value is 330microhenrys (μH) with a 20% tolerance. The figure shows the inductor, L1, along with a DC resistance, R_{dc} , in series with the inductance. The DC resistance is a parasitic effect due to the resistance of the copper windings. Additionally, there are losses associated with the magnetic properties of the material used for the core of the inductor. At DC, the core losses and inductive effects are minimal and the copper loss is dominant. As the frequency increases, the inductive and core loss effects dominate the measurement. Reference resistor, R_s , is used to sense the current through L1. The value for the reference resistor is entered into the parameters tab on the virtual front panel of the analyzer.

For this test, the output signal may be directly connected to the circuit under test. It is recommended that a 50-ohm termination resistor be used at the output of the excitation source. This will insure that the source amplitude displayed in the virtual instrument control window is accurate. It is also useful to connect an

oscilloscope to the output of the source to observe the frequency sweep as the test progresses.

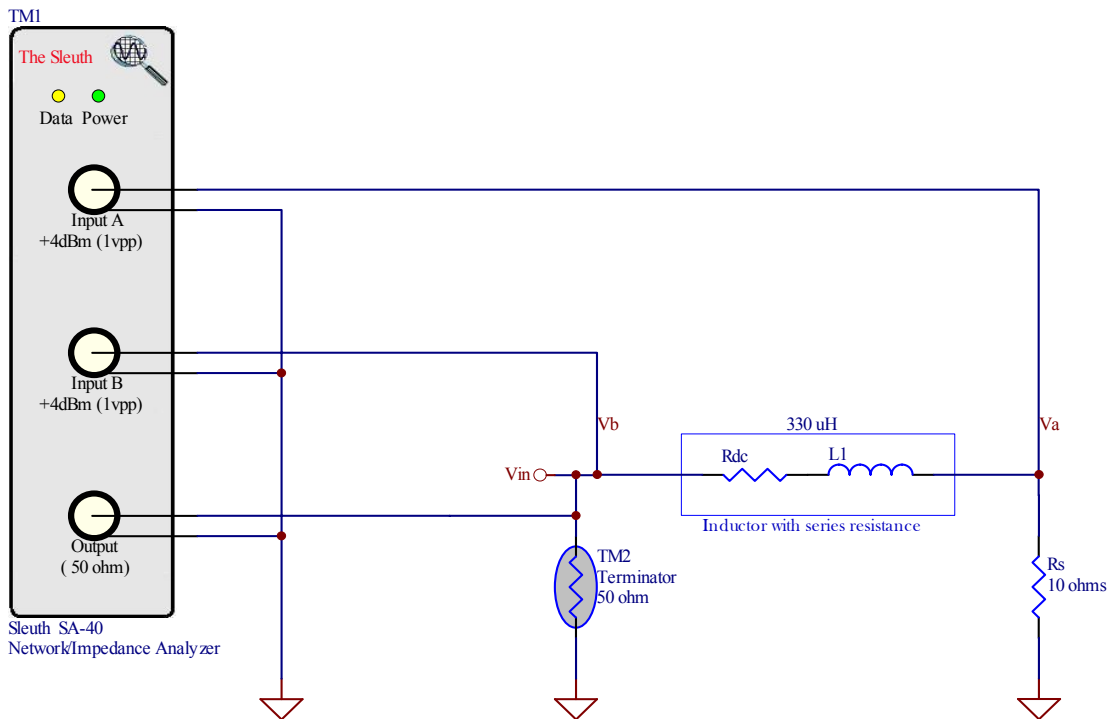

Figure 1. Test setup for measuring an inductor.

Figure 2 illustrates the Circuit Sleuth virtual front panel in the impedance measurement mode. The controls located under the PARAMETERS tab are used to set the analyzer up for the desired frequency range, number of test points, excitation signal amplitude, etc. As shown, measurements will be taken over the frequency range of 100 Hz to 10 Mhz with a logarithmic frequency and magnitude scale.

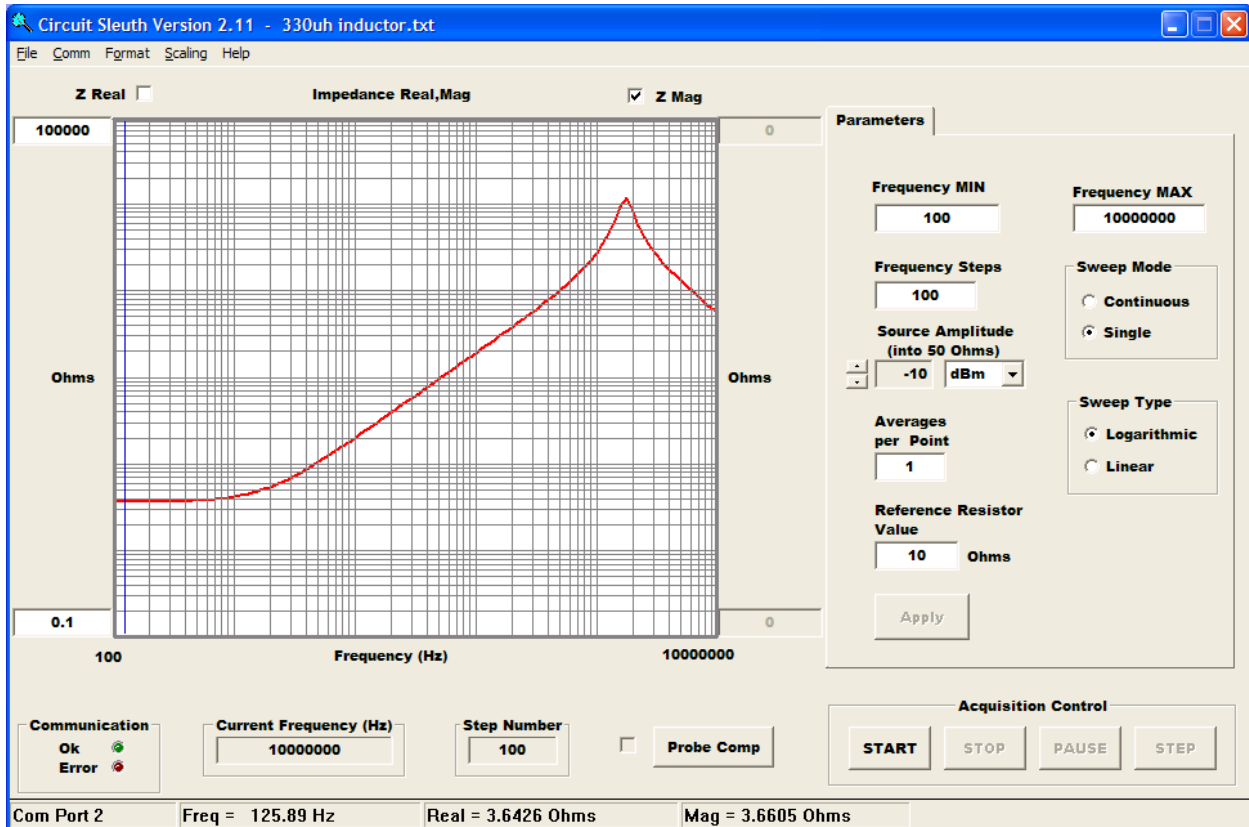

Figure 2. Test results of a 330 uH inductor. The resistance at 125 Hz is 3.66 ohms.

Figure 2 displays the magnitude of the impedance over the frequency range. The flat, low frequency region is where the DC resistance of the inductor is dominant. Clicking on the graph in this region will activate the cursor and display the value of the magnitude (in ohms) in the status bar. Figure 2 shows that the magnitude of the resistance at 125 Hz is 3.66 ohms.

The region of the graph past the knee, where the data seems linear (this is a log-log scale) is where the inductive effect is dominant. If the cursor is placed in this region and a measurement is made, the inductance can be calculated by the following formula:

$$L = \frac{Mag}{2\pi \cdot f} \quad (1)$$

This is shown in Figure 3.

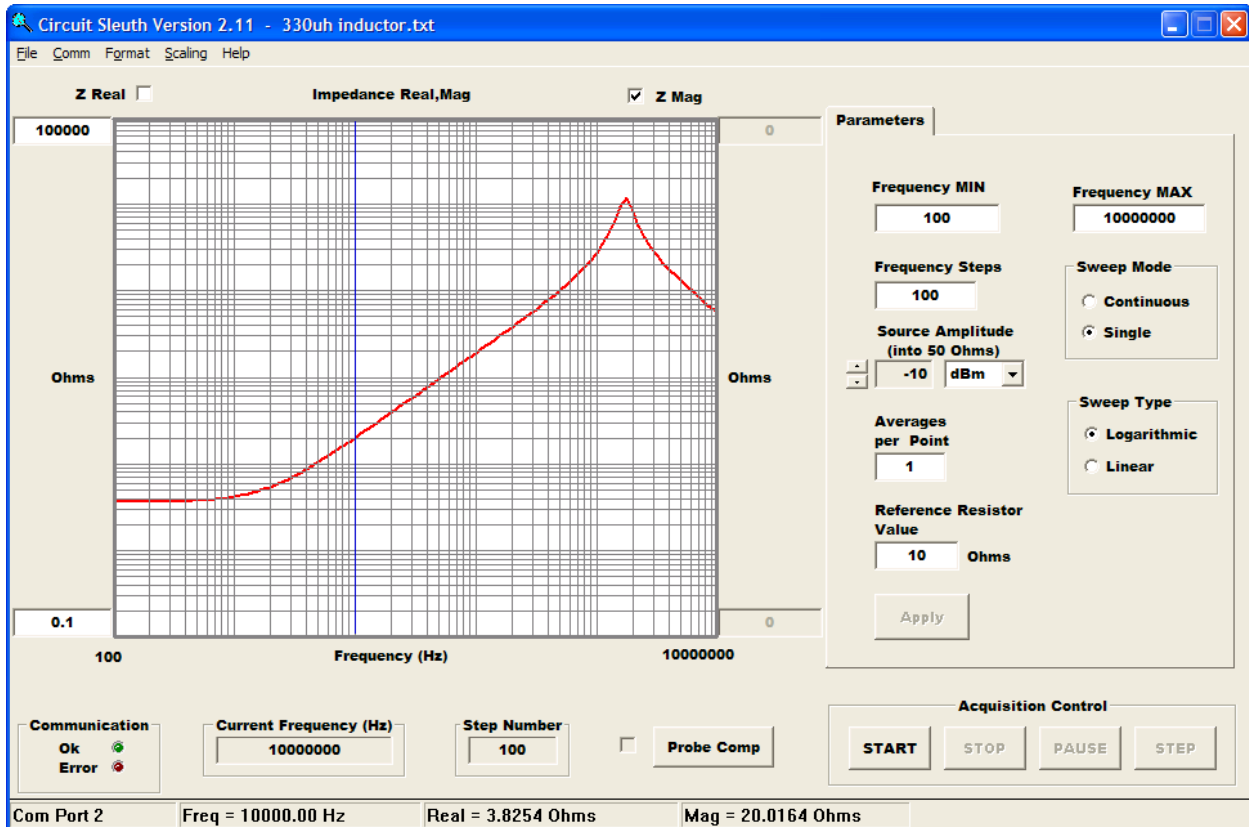

Figure 3. Test results of a 330 uH inductor. The reactance (Mag) at 10Khz is 20 ohms.

The reactance of the inductor is 20 ohms at a frequency of 10Khz. Using the equation above:

$$L = \frac{Mag}{2\pi f} = \frac{20}{2\pi \cdot 10Khz} = 318\mu H \quad (2)$$

This is within the 20% tolerance specified for the part.

The chart of figure 3 illustrates a peaking in the magnitude of the impedance curve. This peaking is due to inter-winding or parasitic capacitance, C_p , which is in parallel with the inductance forming a parallel resonant or “tank” circuit. Figure 4 illustrates the inductor with the DC resistance and the parasitic capacitance included. Using the cursor, the resonant frequency is measured to be 1.77 Mhz.

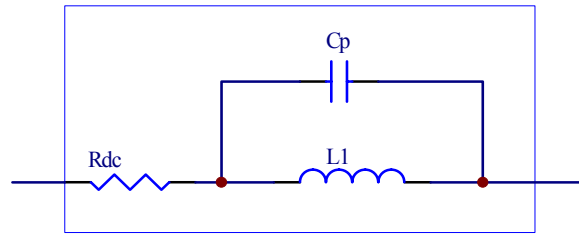

Figure 4. Inductor modeled with series resistance and parasitic capacitance.

The parasitic capacitance can be calculated using the equation for LC resonance:

$$f_r = \frac{1}{2\pi\sqrt{LC_p}} \quad (3)$$

where

$$C_p = \frac{\left[\frac{1}{2\pi \cdot f_r}\right]^2}{L} = \frac{\left[\frac{1}{2\pi \cdot 1.77 \cdot 10^6}\right]^2}{318 \cdot 10^{-6}} = 25.4 \cdot 10^{-12} \quad (4)$$

The model of the inductor along with its DC resistance and parasitic capacitance is shown in figure 5.

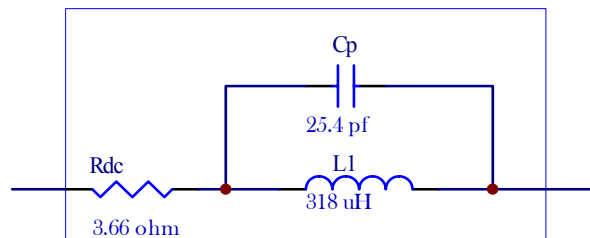

Figure 5. Inductor modeled with values for inductance, DC resistance and parasitic capacitance.

The model can be used in a simulation package to accurately predict circuit performance.

Transformer impedance measurement and the equivalent circuit model.

The schematic symbol of a transformer and its associated circuit model is shown in figure 6.

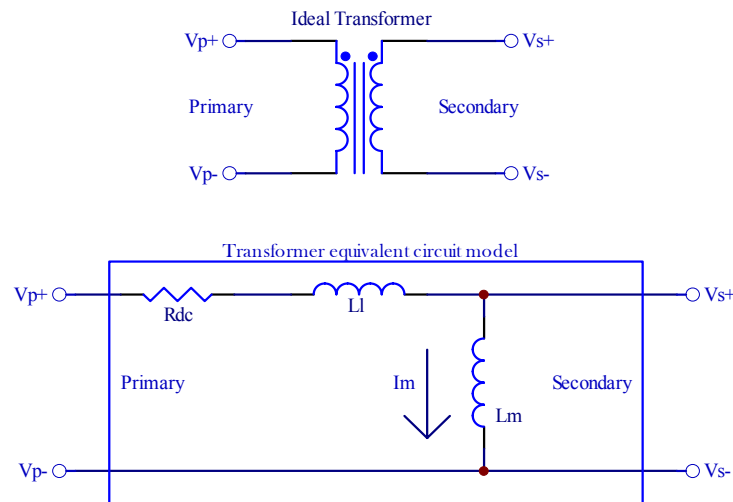

Figure 6. Schematic symbol of an ideal transformer and its associated circuit model.

The given circuit represents a simplified transformer model referenced from the primary side. It is recognized that detailed transformer models exist that include many more components and parameters. The model shown indicates those components that characterize the operation of the transformer (magnetizing inductance) along with components that characterize some first order parasitic effects such as DC resistance and leakage inductance. Additionally, the measured values are useful for characterizing the operation of the transformer in a circuit simulation package.

The magnetizing inductance, L_m , works with the magnetizing current, I_m , to produce the flux field in the transformer core. Since the transformer secondary is wound on the same core, the power from the primary is coupled to the secondary via the flux field.

The leakage inductance, L_l , and DC resistance, R_{dc} , are parasitic components. Leakage inductance is a measure of how well the windings are coupled together. In a properly designed transformer, L_l would be much smaller than L_m .

The DC resistance is a parasitic effect due to the resistance of the copper windings.

Two different test configurations will be used to characterize the transformer:

1. Measurement of magnetizing inductance (L_m),
2. Measurement of Leakage inductance, (L_l), and DC resistance (R_{dc})

Figure 6 indicates that the only accessible ports on the transformer are V_{p+} , V_{p-} , V_{s+} and V_{s-} . The characteristic components are measured by accessing these ports.

Measuring the magnetizing inductance, L_m .

The magnetizing inductance is the mutual inductance of the winding. It is generally much higher than the leakage inductance. Referring to figure 6, notice that the characteristic components are connected in series between V_{p+} and V_{p-} . Since inductances and resistance connected in series are added together and the contributions of R_{dc} and L_l are small with respect to L_m , the characteristic component of L_m will dominate the measurement. The test setup is shown in figure 7.

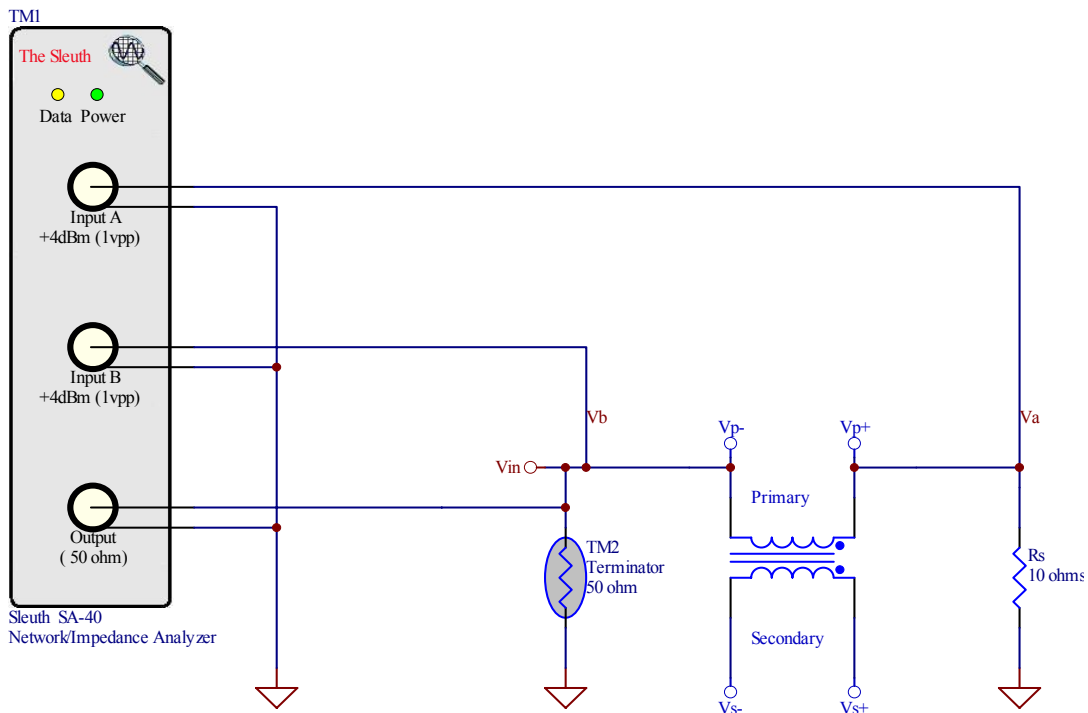

Figure 7. Test setup for measurement of magnetizing inductance, L_m .

Figure 8 illustrates the test results for the magnetizing inductance, L_m . The Circuit Sleuth virtual front panel is in the impedance measurement mode. The controls located under the PARAMETERS tab are used to set the analyzer up for the desired frequency range, number of test points, excitation signal amplitude, etc.

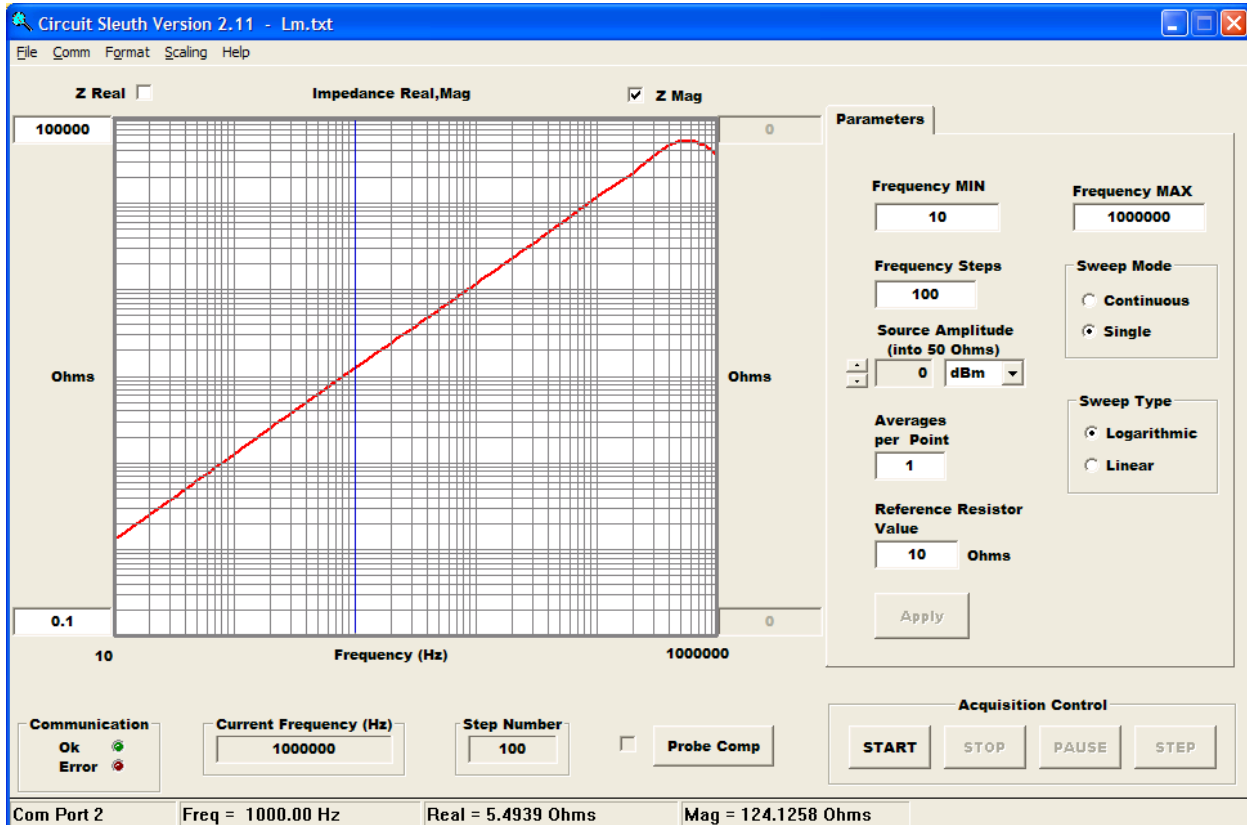

Figure 8. Virtual front panel display of the test results for the magnetizing inductance, L_m .

The cursor is positioned at 1kHz. The value of the frequency and the magnitude (in Red) of the impedance are displayed in the status bar. The impedance displayed is 124.1 ohms at 1kHz. The inductance is calculated with eq. (1).

Frequency	Impedance (ohms)	Calculated Inductance (mH)
100 Hz	12.7	20.2
1000 Hz	124.1	19.8
100000 Hz	11714	18.6

The average value for L_m is **19.53 mH**.

Leakage inductance, L_l , and DC resistance, R_{dc} .

Leakage inductance gives an indication of the quality of the magnetic coupling between the windings. The closer the magnetic coupling between the windings, the smaller the leakage inductance value. Leakage inductance can be managed and/or reduced to some degree by winding the transformer using various techniques that improve the coupling between windings. In switching power supplies, leakage inductance is undesirable because it can cause high voltage spikes on the driver circuit and lower efficiency.

The DC resistance is the resistance of the copper wire used for the winding. This can be calculated by knowing the length of the wire and the resistance/ft of the wire being used. Power supply designers attempt to minimize the DC resistance in transformers and inductors because it wastes power and lowers the efficiency of the supply especially in high current applications.

The leakage inductance of the transformer is measured using the same test setup of figure 7 and shorting together the secondary winding. This effectively shorts out the effect of the magnetizing inductance leaving the series circuit of the DC resistance and the leakage inductance. At low frequencies, the DC resistance will dominate the measurement. At high frequencies, the leakage inductance (L_l) will dominate the measurement. The test setup with the transformer secondary shorted is shown in figure 9.

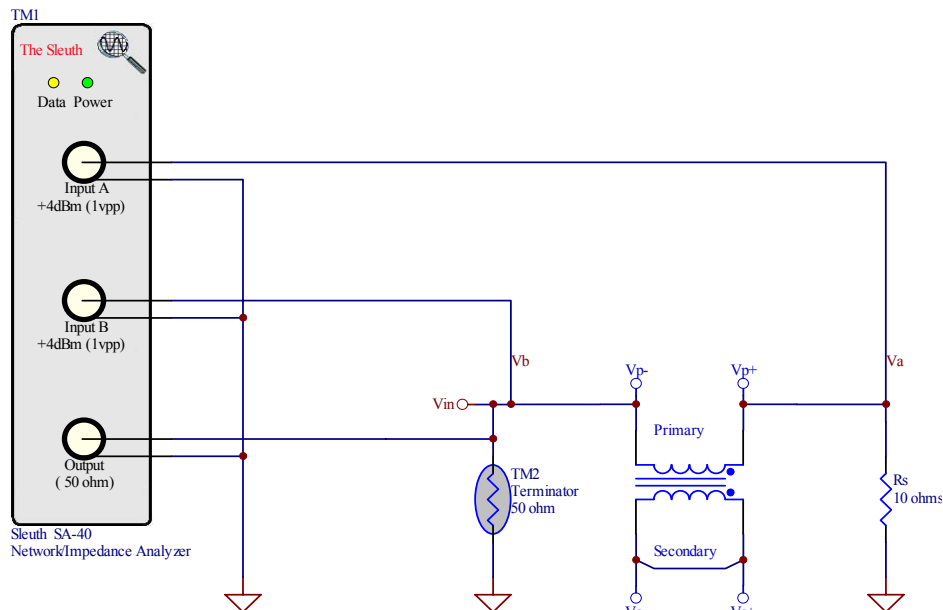

Figure 9. Test setup for measurement of leakage inductance, L_l , and DC resistance, R_{dc} . The transformer secondary is shown shorted.

Figure 10 illustrates the test results for the leakage inductance, L_l and the DC resistance, R_{dc} . The Circuit Sleuth virtual front panel is in the impedance measurement mode.

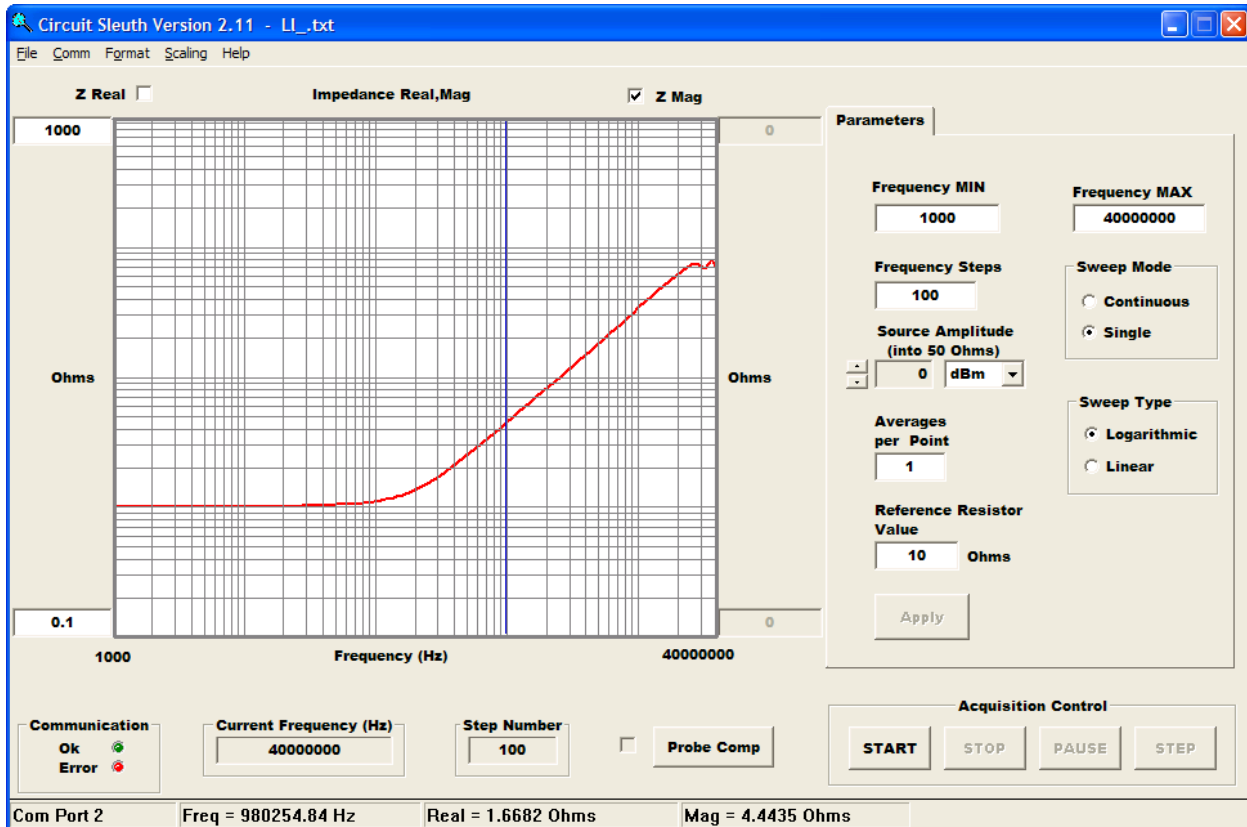

Figure 10. Virtual front panel display of the test results for the leakage inductance, L_m , and the DC resistance, R_{dc} .

The impedance displayed is 4.4 ohms at 980254 Hz. The inductance is calculated with eq. (1).

Frequency	Impedance (ohms)	Calculated Inductance (μH)
980254 Hz	4.4	0.71
2058179 Hz	7.9	0.61
10087701 Hz	33.0	0.52

The average value of L_l is **0.61 μH** and the measured R_{dc} is **0.99 Ohms**.

The model of the transformer with the values of the characteristic components is shown in figure 11.

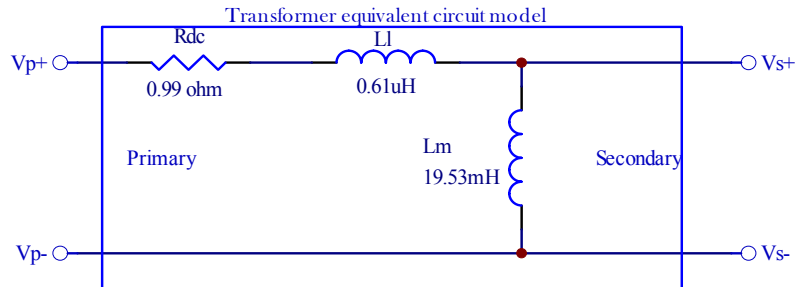

Figure 11. Transformer modeled with values for L_l , DC resistance and L_m .

The model can be used in a simulation package to accurately predict circuit performance.

Summary

This application note showed how to measure the impedance characteristics of an inductor and a transformer.

The inductor measurement discussed the effects of the inductance value, DC resistance and parasitic capacitance.

The transformer characteristics, although inductive in nature, presented a slightly different measurement challenge because in addition to the DC resistance, two inductances, magnetizing inductance, L_m and leakage inductance, L_l must be considered. Physical models for both the inductor and transformer, along with component values were derived and can be used in simulation packages to better predict theoretical circuit behavior.

