

Characterization of an RLC Low pass Filter

John F. Iannuzzi

Introduction

Inductor-capacitor low pass filters are utilized in systems such as audio amplifiers, speaker crossover circuits and switching power supply designs. Audio systems use low pass filters to bypass power supply noise and to control surge currents. Speaker crossover systems, because of their high power requirement use LC filters to block low frequency power surges to the midrange and high frequency speaker sections. In many cases, the output filter of a switching power supply must use a custom wound inductor with a standard capacitor for optimal design and efficiency. Because of this, the filter must be completely characterized with all values and parasitic effects accounted for to insure the stability of the feedback control system. The parasitic effects include the DC resistance of the inductor and the ESR of the capacitor.

This application note, along with AN-1 and AN-3 discusses a method for characterizing an RLC filter transfer function using the Circuit Sleuth Network/Impedance analyzer.

Note from the Author. Commercial inductor and capacitor values are known for extremely wide tolerances. A concern is the use of these components in control systems where designs must be extremely robust, sacrificing bandwidth/performance for stability because of the inductor and capacitor tolerance stack up. Additionally, it also leads to the conclusion among engineers that it is impossible to get the measurements to agree closely with the theoretical calculations or the results of a simulation. Because of this, theoretical calculations and simulations are never performed because they are deemed unreliable. This application note was written to illustrate that when the actual components are characterized, accurate theoretical predictions and simulations are possible. This does not exclude the fact that the designs must also be built, tested and compared to the theoretical models. By this, the design has increased reliability, improved quality and outstanding performance.

RLC filter transfer function, V_{out}/V_{in}

Figure 1 represents an RLC filter along with some series damping resistance and an external sine wave voltage source.

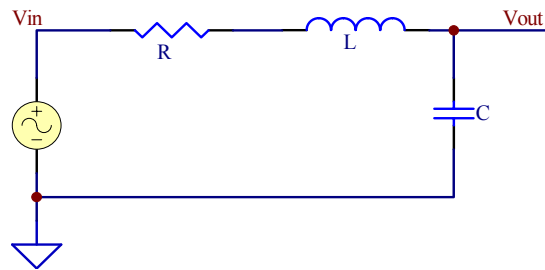

Figure 1. Schematic of RLC low pass filter.

The classic transfer function of the RLC filter is a second order system that is described mathematically as:

$$\frac{V_{out}}{V_{in}} = \frac{\omega^2}{s^2 + 2\xi\omega \cdot s + \omega^2} \quad (1)$$

where:

$$\omega^2 = \frac{1}{LC} \quad (2)$$

and

$$2\xi\omega = \frac{R}{L} \quad (3)$$

Where R,L and C are the component values, 's' is a complex vector, 'ω' is the angular frequency and 'ξ' is the damping factor. The damping factor resistance is included as a single resistance. This resistance is serving as a placeholder for the parasitic resistances that are always physically present in an inductor and a capacitor.

The parasitic resistance present in an inductor is its "DC" resistance. This resistance is dependent on the amount of copper present in the inductor winding. It is dominant at relatively low frequencies and can be measured at the low frequency end of the inductor's impedance curve. The parasitic resistance of a capacitor is called the equivalent series resistance, or ESR. The ESR of a capacitor is dominant at the high frequency end of a capacitor's

impedance curve. In the following sections, both the inductance value and capacitor value, along with their associative parasitic resistances, will be characterized and placed into the circuit model. Since both of the parasitic resistances are in series, they will be lumped together and represented as a single resistor for the analysis.

Measuring the inductor, L

AN-1 details the techniques used for measuring the impedance of an inductor. The same techniques were used to measure the inductor for this application note. The Circuit Sleuth virtual front panel results for that inductor are shown in figure 2. The inductance value is calculated from the magnitude. The magnitude is 5.38 ohms @ 10 KHz.

$$L = \frac{Mag}{2\pi \cdot f} = \frac{5.38}{2\pi \cdot 10000} = 85.7 \mu H \quad (4)$$

The resistance associated with the copper loss in the inductor windings or DC resistance is measured as 0.04 ohms @ 200 Hz.

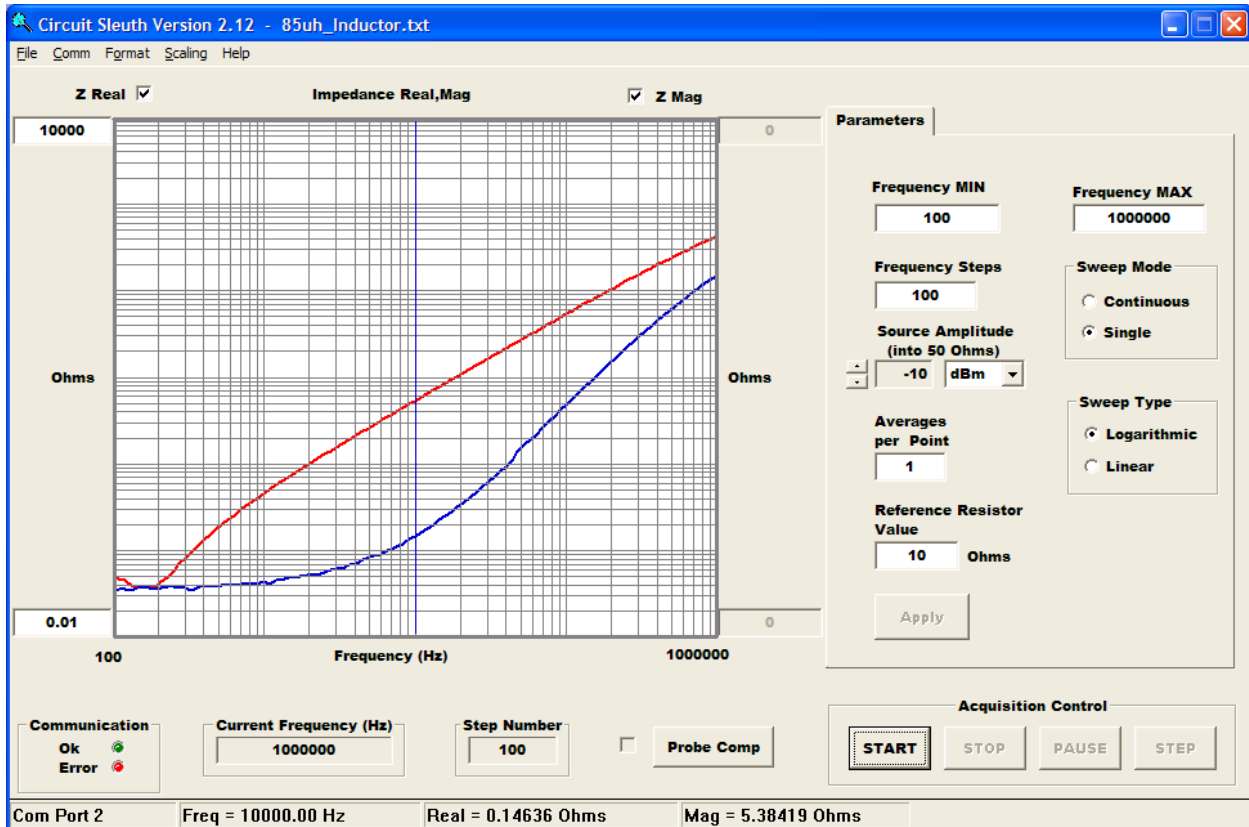

Figure 2. Test results of an 85 uH inductor. The cursor is positioned at 10 KHz. The magnitude (RED) @ 10 KHz is 5.38 ohms.

Measuring the capacitor, C

AN-3 details the techniques used for measuring the impedance of a capacitor. The same techniques were used to measure the capacitor for this application note. The Circuit Sleuth virtual front panel results for the capacitor are shown in figure 3. The capacitance value is calculated from the magnitude.

The magnitude is 19.05 ohms @ 10 KHz.

$$C = \frac{1}{2\pi \cdot f \cdot \text{Mag}} = \frac{1}{2\pi \cdot 10000 \cdot 19.05} = 0.84 \mu\text{F} \quad (4)$$

The resistance associated with the capacitor ESR is measured at about 3.2 ohms @ 0.9 MHz.

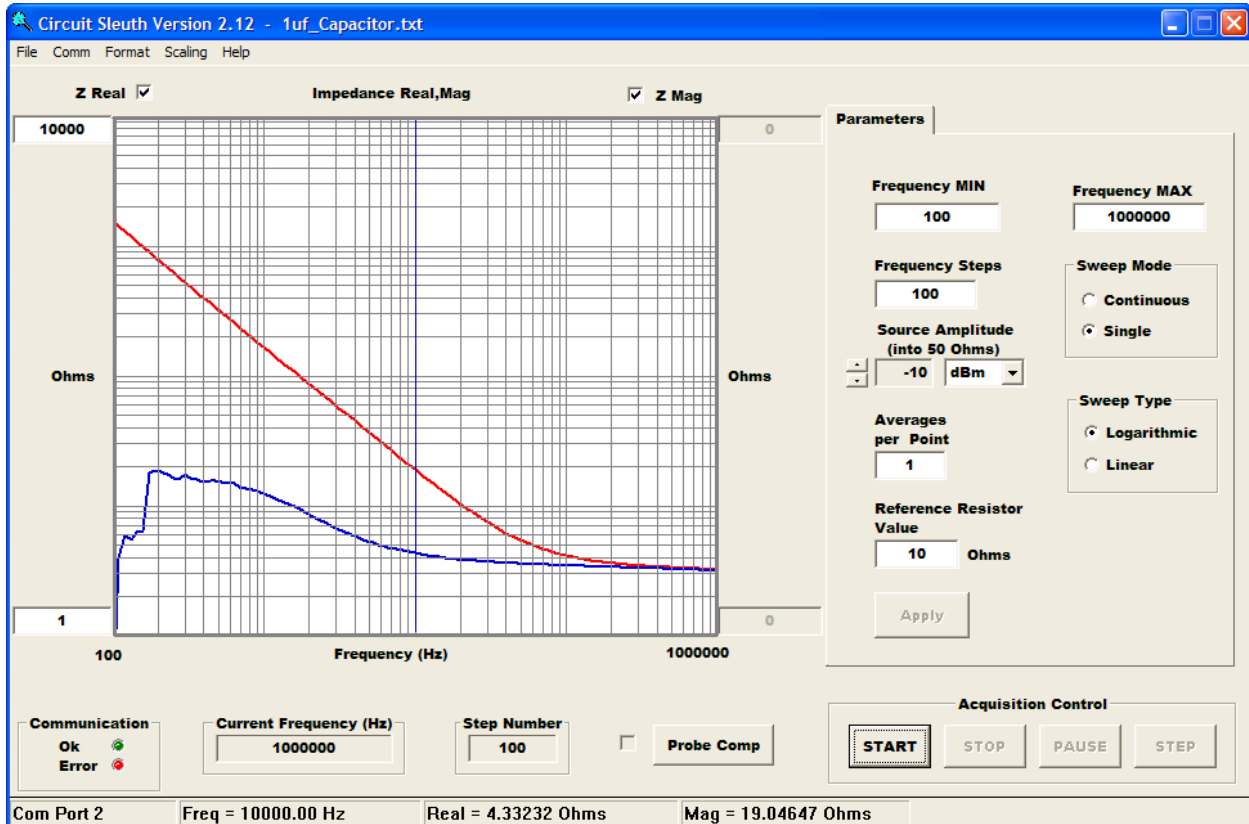

Figure 3. Test results of a 1 uF electrolytic capacitor. The cursor is positioned at 10 KHz. The magnitude (RED) @ 10 KHz is 19.05 ohms.

Adding values to the filter model

Figure 4 illustrates the model of the RLC filter with the component values as determined by the preceding impedance measurements.

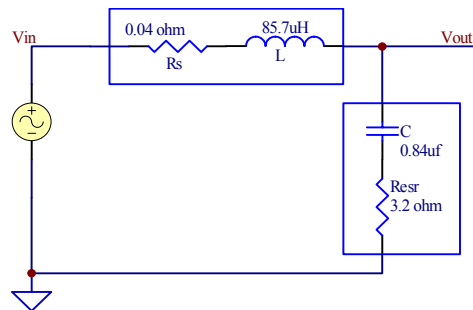

Figure 4. RLC filter with component values.

Since R_s and R_{esr} are in series with the circuit, they can be added together and represented as a single resistor, R . This is shown in figure 5.

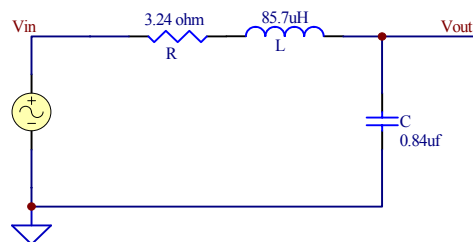

Figure 5. RLC filter with R represented as a lumped value of $R_s + R_{esr}$.

It is now possible to calculate the resonant frequency and the damping factor of the filter.

Resonant frequency:

$$\omega = \sqrt{\frac{1}{LC}} = \sqrt{\frac{1}{85.7 \cdot 10^{-6} \cdot 0.84 \cdot 10^{-6}}} = 118170.76 \text{ rad / sec} \quad (5)$$

$$f = \frac{\omega}{2\pi} = 18.817 \text{ KHz} \quad (6)$$

Damping factor:

$$\xi = \frac{R}{2\omega L} = \frac{3.24}{2 \cdot 118170.76 \cdot 85.7 \cdot 10^{-6}} = 0.16 \quad (7)$$

Measuring the filter

The test setup for measuring the transfer function of the RLC filter is shown in figure 6. It is also useful to connect an oscilloscope to the output of the source to observe the frequency sweep as the test progresses.

Note that the resistance, R, is actually the parasitic resistances of the capacitor and inductor. IT IS NOT AN ACTUAL RESISTOR TO BE CONNECTED.

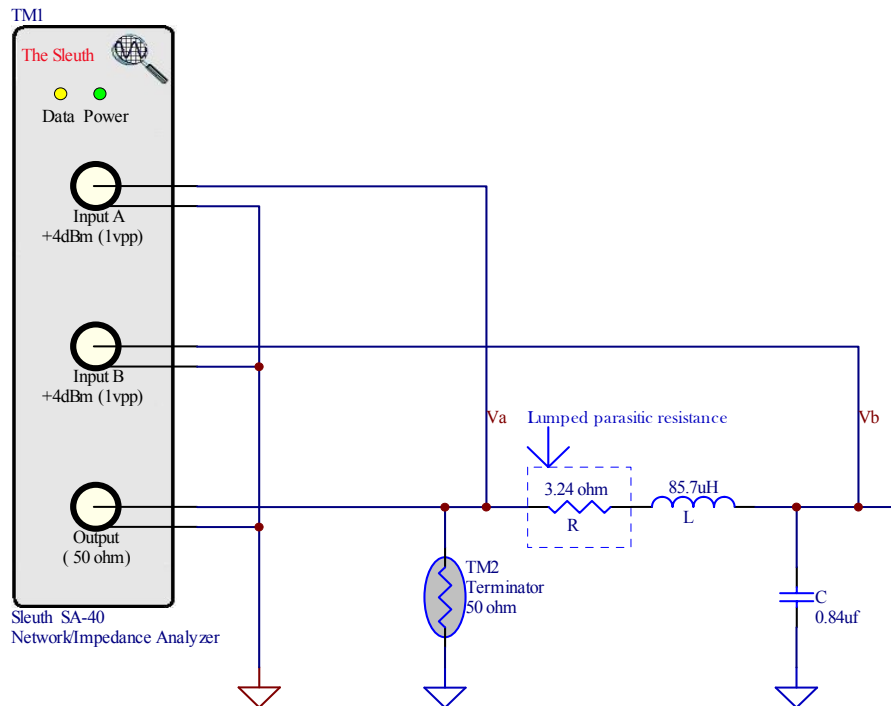

Figure 6. Test setup to measure the transfer function of the RLC filter, with the parasitic resistance, R, shown.

Figure 7 illustrates the Circuit Sleuth virtual front panel in the ratio (B/A) measurement mode. The controls located under the PARAMETERS tab are used to set the analyzer up for the desired frequency range, number of test points, excitation signal amplitude, etc. As shown, measurements were taken over the frequency range of 100 Hz to 1 Mhz with a logarithmic frequency and magnitude scale.

In this mode, the magnitude and phase (bode diagram) of the system response is displayed. This is also known as the system transfer function. The transfer function shows the output/input relationship of the system over frequency. The magnitude is best represented in decibels and the phase in degrees. This particular filter is very flat in the pass band, peaks at resonance and rolls off at the high frequency end. Adding additional damping resistance will attenuate the resonant peak. As mentioned in the introduction, in switch mode power supply design, it is very important to know the transfer function of the output filter because it can significantly affect the stability of the feedback control system that regulates the output voltage.

The cursor is placed at the peak point in the transfer function. This is the filter's resonant frequency. The measured frequency of resonance is about 18.2 KHz and is within 3.2% of the calculated frequency of 18.8 KHz. Not bad!

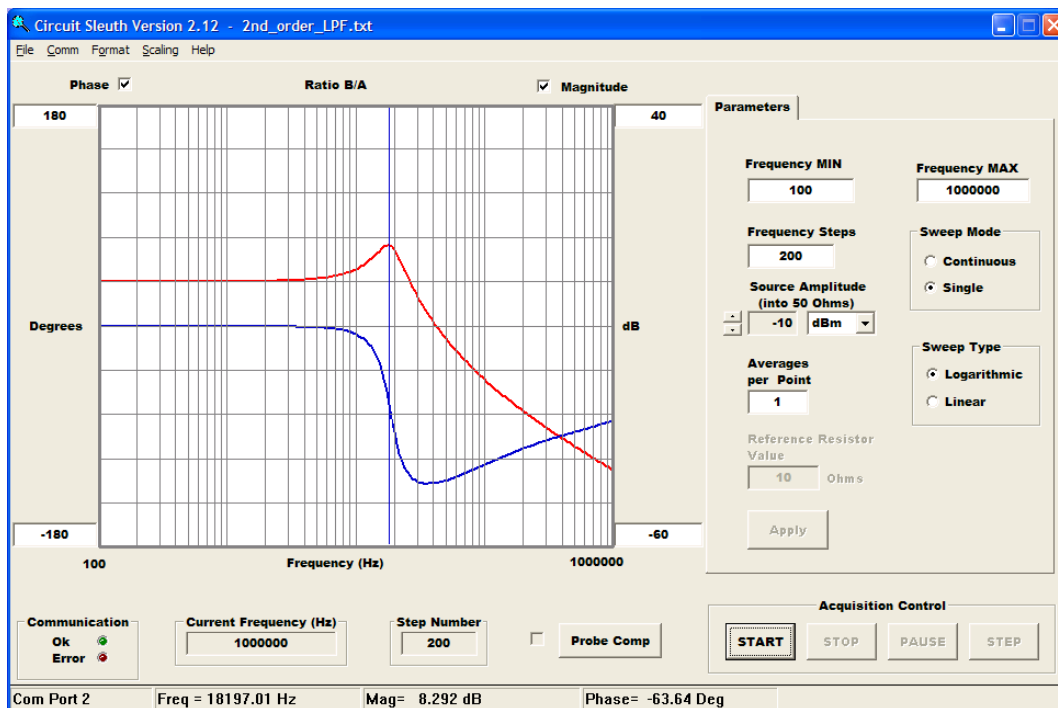

Figure 7. Virtual front panel output displaying the transfer function, magnitude and phase, of the RLC filter.

Figure 8 illustrates the magnitude vs. normalized frequency at various damping factors. The calculated damping factor of 1.6 compares favorably to the magnitude measured at the resonance frequency of about 8.3 dB.

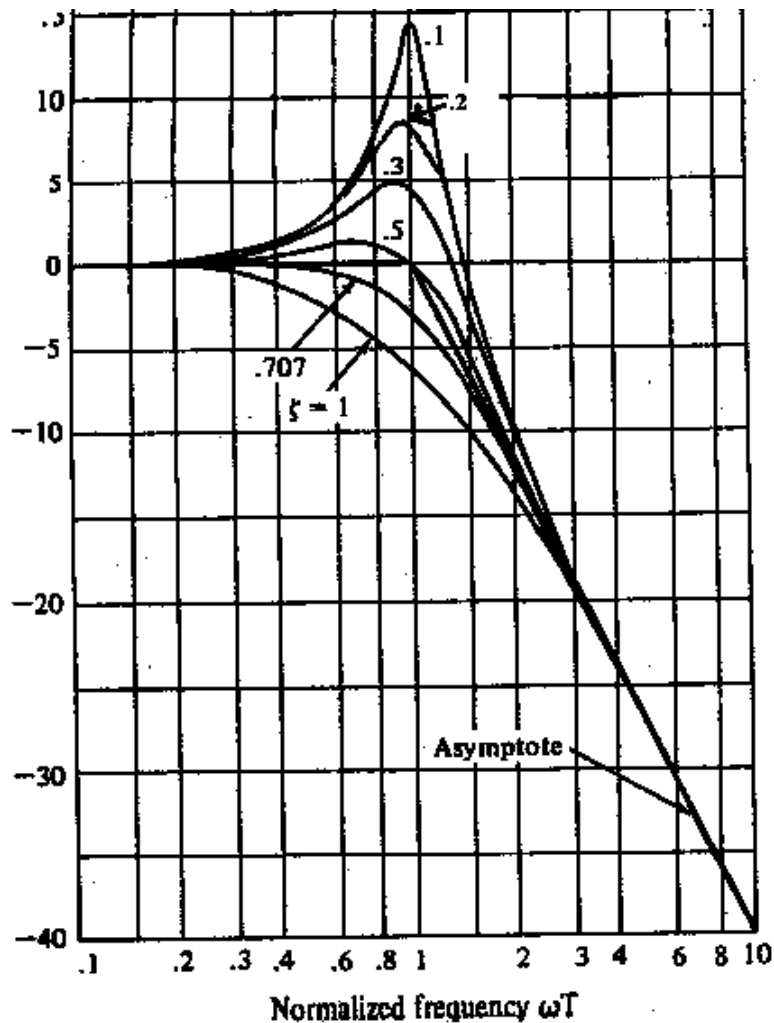

Figure 8. Magnitude vs. normalized frequency for various damping factors.

Summary

This application note showed how to measure and verify the transfer function of an RLC low pass filter. Theoretical calculations were performed initially using the standard second order system transfer function to find expressions for the frequency of resonance and the damping factor of the filter. The characteristic impedances of the inductor and the capacitor were measured and the parasitic resistances of those components were lumped together in series to form the damping resistance of the filter. The transfer function of the filter was characterized with a network analyzer. The frequency of resonance and the

amplitude in dB at the point of resonance was measured. The measured resonance frequency was within 3.2% of the calculated value. The damping factor was estimated using the measured amplitude peak in dB of the magnitude curve at the point of resonance and comparing that magnitude to a normalized chart. It was determined that the calculated damping factor of 1.6 compared favorably to that indicated on the chart.